



## STREAMLINING CONCEPT STRUCTURE ENGINEERING FOR FASTER, SMARTER DEVELOPMENT



**Stefan  
MERTZ**

CATIA Engineering Industry  
Process Expert Senior  
Specialist  
Dassault Systèmes



**Michel  
SCHÄFER**

CATIA Engineering  
Industry Process  
Consult Manager  
Dassault Systèmes

# EFFICIENT ENGINEERING WITH MODELING & SIMULATION

## Streamlining Concept Structure Engineering for Faster, Smarter Development

Michel Schäfer  
CATIA WW Industry Process Success Manager

Stefan Mertz  
CATIA WW Senior Industry Process Expert



# CONTENT

- **Concept Engineering Introduction**
- **Modules & Interface Functionalities**
- **Generic Skeleton Body Model**

# CHALLENGES



AVAILABILITY OF CONCEPT MODEL FOR SIMULATION



DISCONNECTED TOOLS



COLLABORATION



TIME & RESOURCE CONSTRAINTS

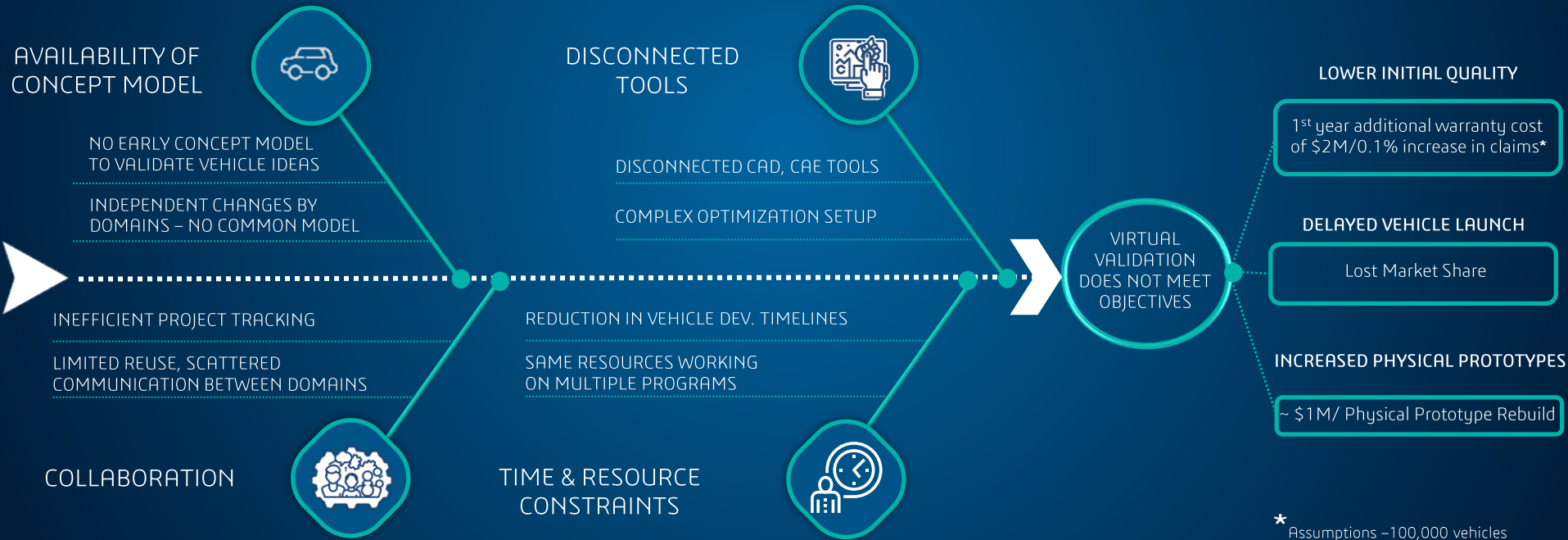

\* Assumptions – 100,000 vehicles sold in the year for \$20,000 each

# CHALLENGES



AVAILABILITY OF CONCEPT MODEL FOR SIMULATION



DISCONNECTED TOOLS



COLLABORATION



TIME & RESOURCE CONSTRAINTS

**SOLUTION :**



**Concept Engineering**

Flexible and robust parametric design



Fast and collaborative modeling



Associativity of design and simulation



Process automation and design exploration



**Harmonized end-to-end platform**



# CHALLENGES



AVAILABILITY OF CONCEPT MODEL FOR SIMULATION



DISCONNECTED TOOLS



COLLABORATION



TIME & RESOURCE CONSTRAINTS

## SOLUTION: Concept Engineering | Key Differentiators

### RESILIENT DESIGN



UPDATE STRATEGIES TO ENSURE MODEL ROBUSTNESS AND FLEXIBILITY



### WATERTIGHT MODULES

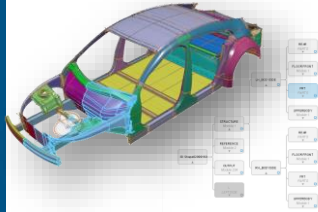

MODULES CAN BE RE-USED, RE-POSITIONED, RE-CONNECTED



### INTERFACES & MAPPING

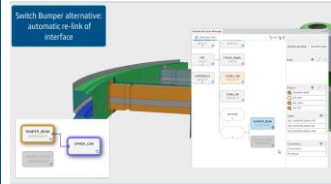

SEMANTIC INTERFACES TECHNOLOGY FOR AUTOMATIC ASSEMBLY



### PROPERTIES as Attributes

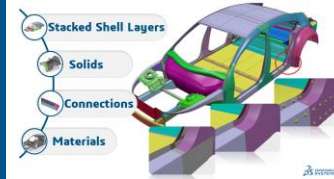

FUNCTIONALITY TO CREATE MULTI-LAYER DESIGNS FROM SINGLE-LAYER 3DEXPERIENCE SURFACES

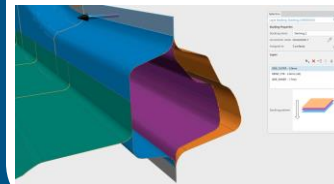

### SIMULATION & EXPLORATION

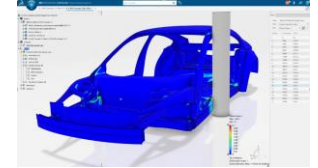

READY-TO-SIMULATE MODELS - BASED ON STACKING, MATERIAL THICKNESS & CONNECTION PROPERTIES

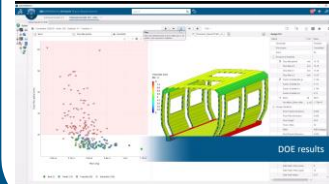

# MODULES AND INTERFACES

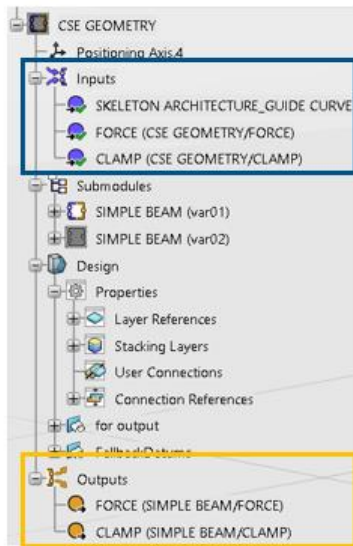

A **module** is a container for:

- ✓ Any geometries (wireframe, surfaces and solids)
- ✓ Can contain sub-modules
- ✓ Properties for materials, layers, stackings and connection
- ✓ Parameters and formulas
- ✓ Using **Input interfaces** (Inputs) and **Output interfaces** (Outputs)
- ✓ Support switching of module alternatives and excluding them from the design

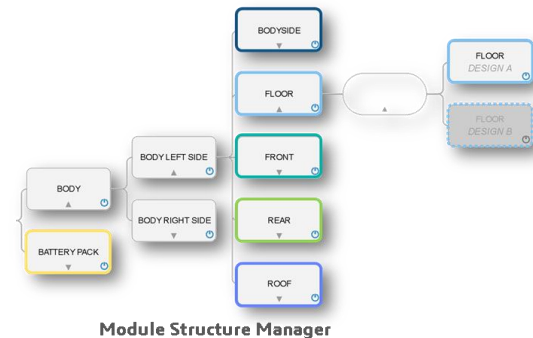

## Input interfaces

Input information for the design of the module

- ✓ Parameters
- ✓ Geometry features
- ✓ Interfaces for mapping (projection technology)



## Output interfaces

Output information of the design of the module

- ✓ Parameters
- ✓ Geometry features
- ✓ Interfaces for mapping (projection technology)

# MODULES FEATURE DEMO

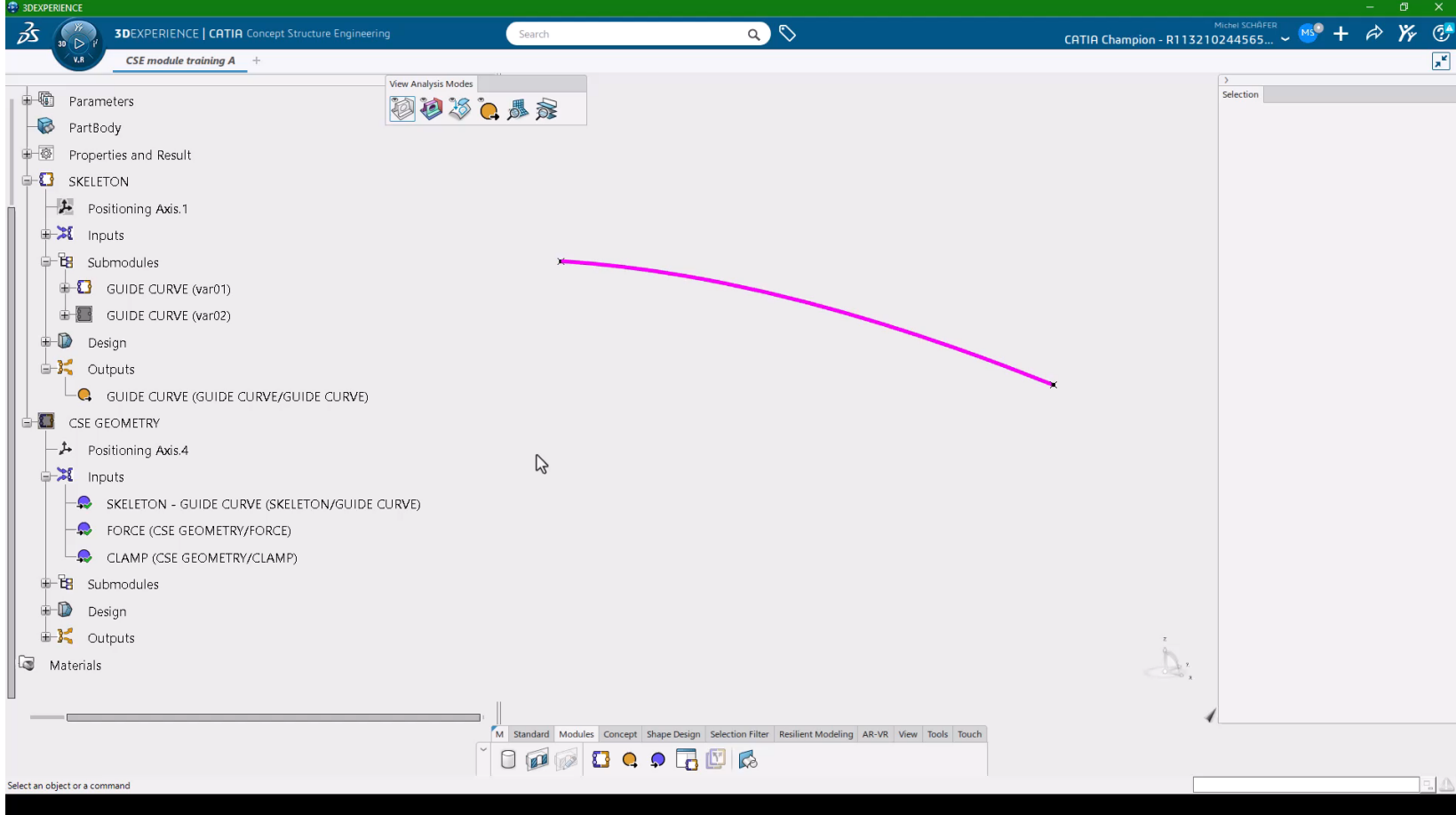



# Product development

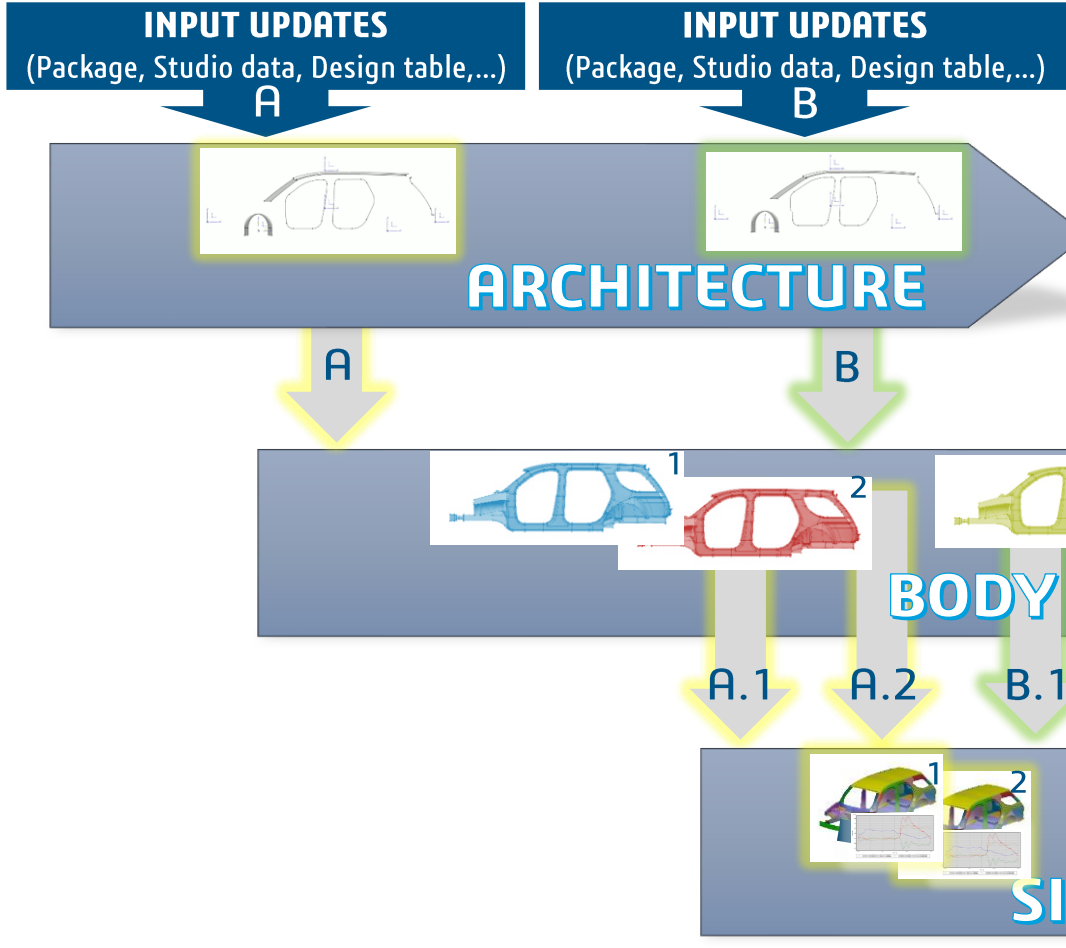

FINAL CONCEPT

# Product development

INPUT UPDATES (Package, Studio data, Design table, ...)

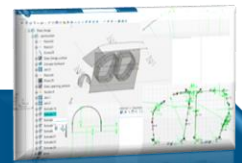

TEMPLATE of Archetypes



ARCHITECTURE



TEMPLATE of Modules

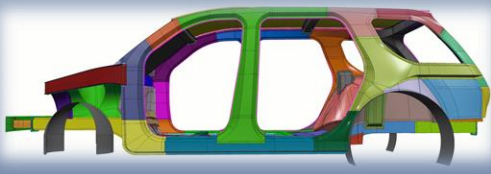

BODY DESIGN

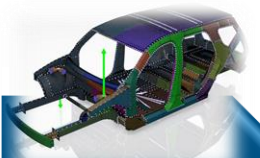
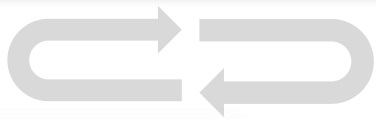

TEMPLATE of Scenarios

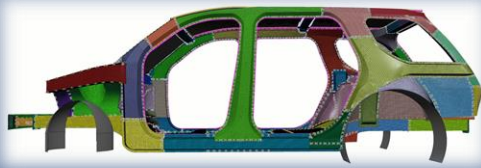

SIMULATION

FINAL CONCEPT



FINAL CONCEPT

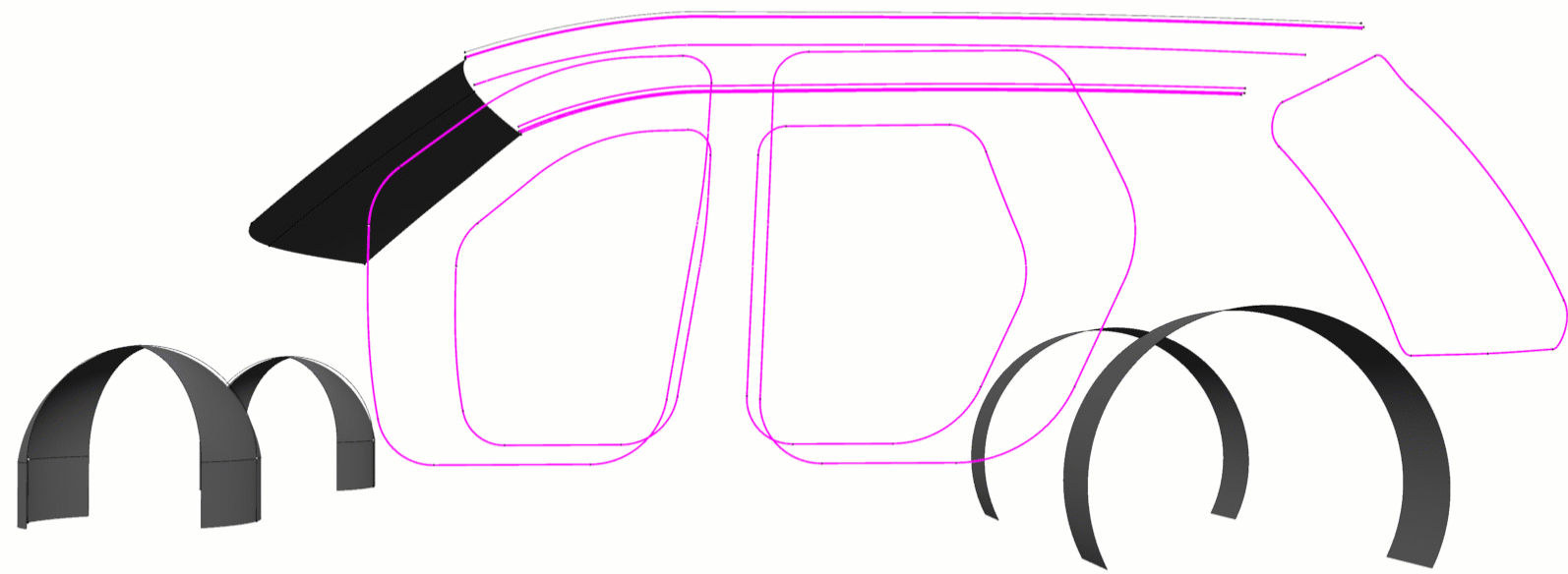



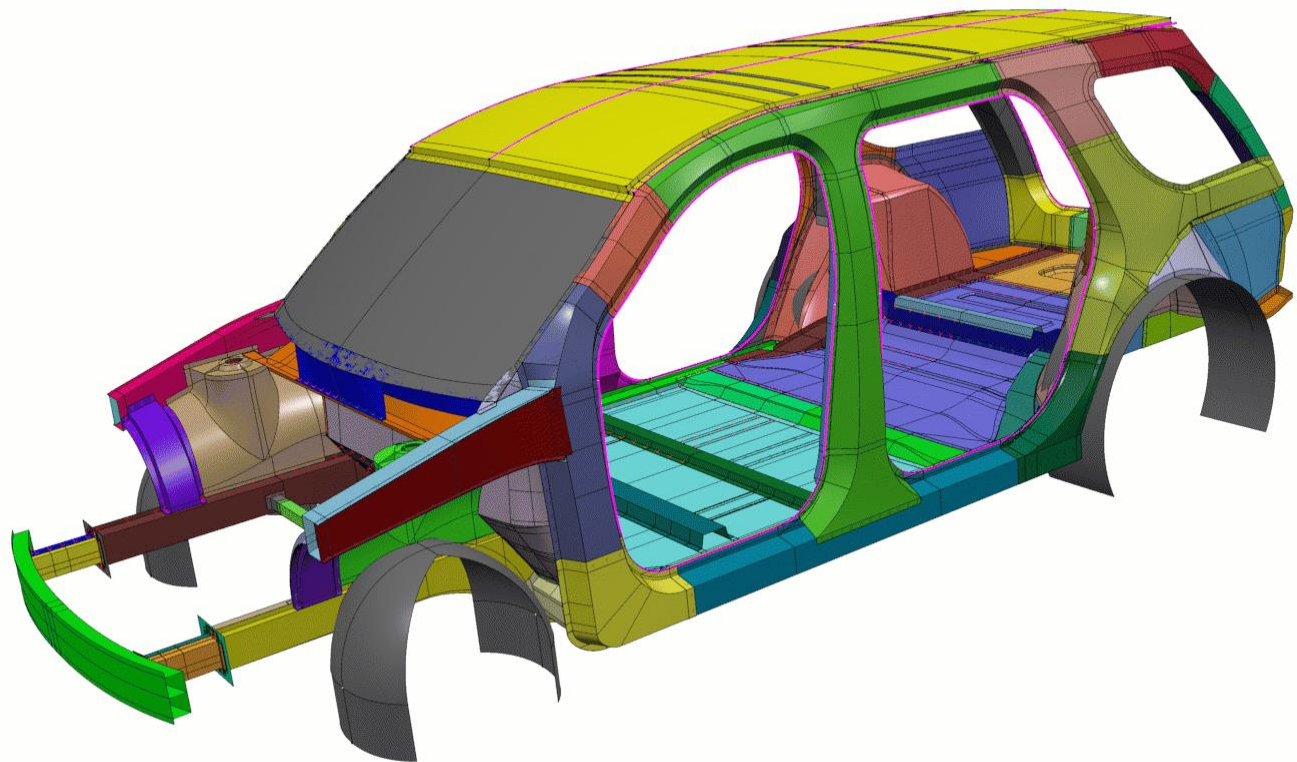

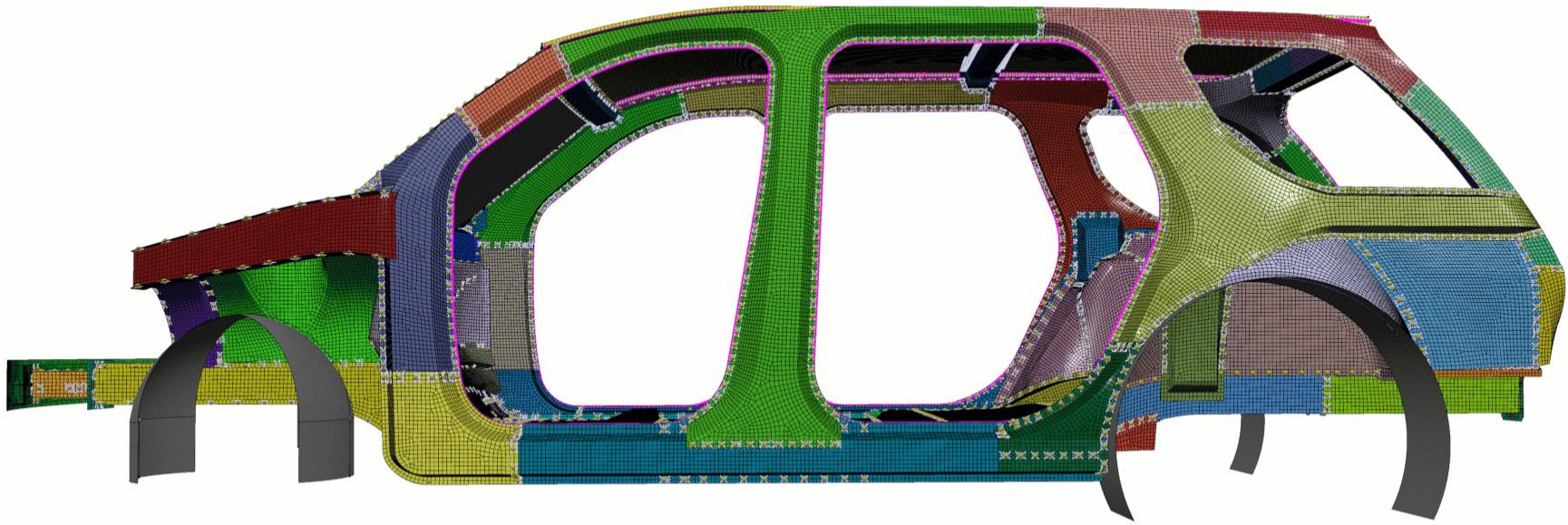

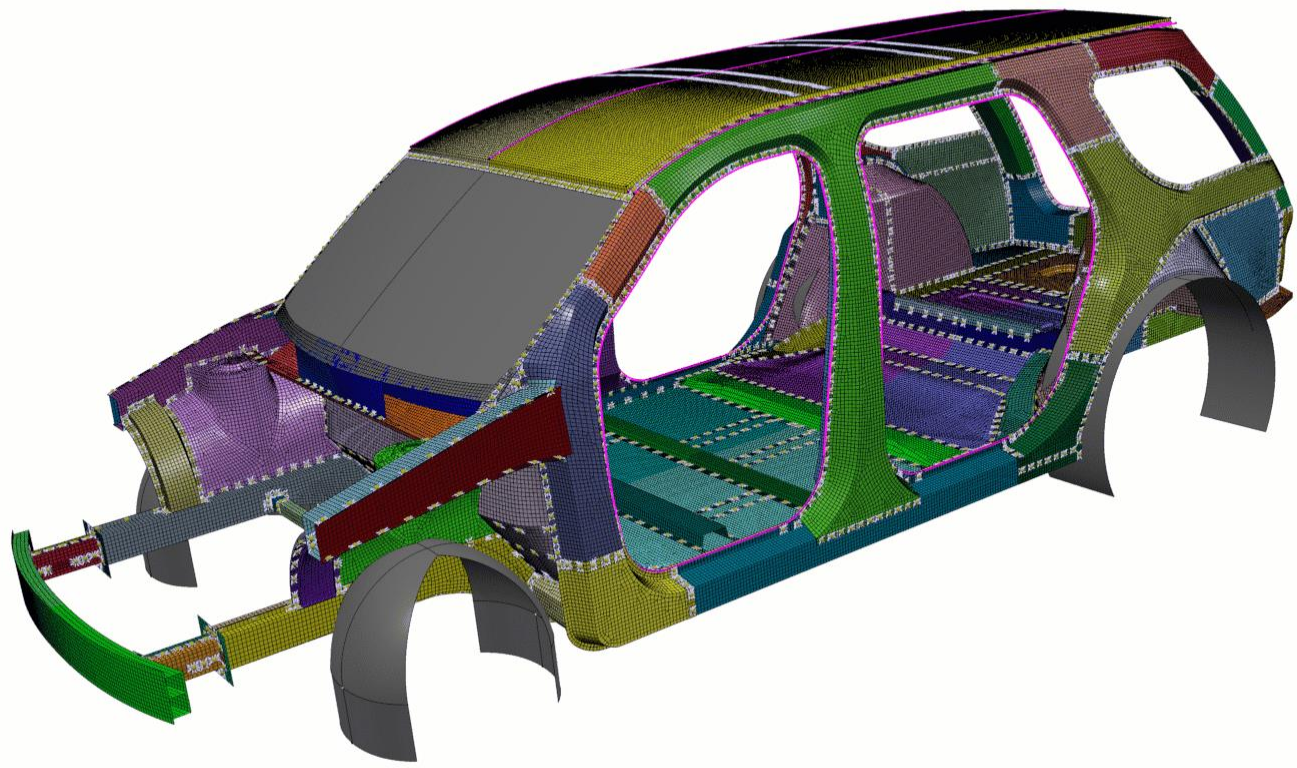

# REAR OVERHANG

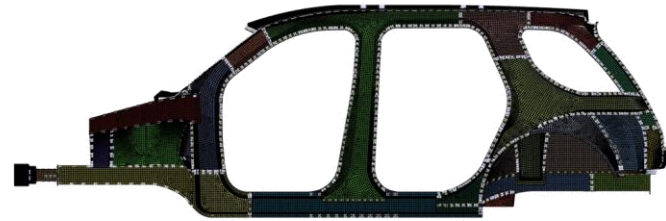
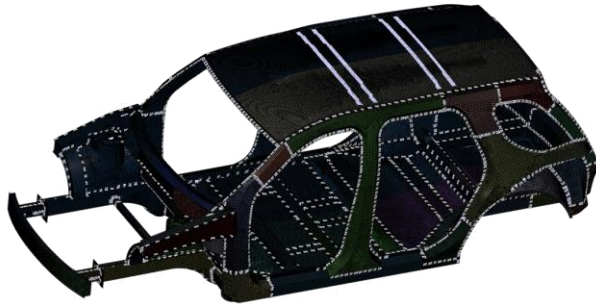
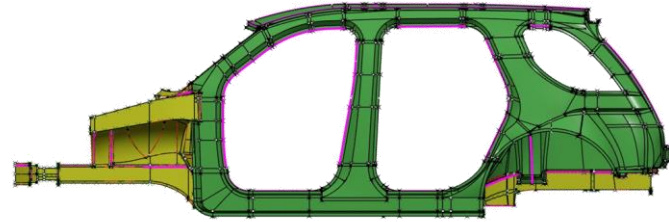
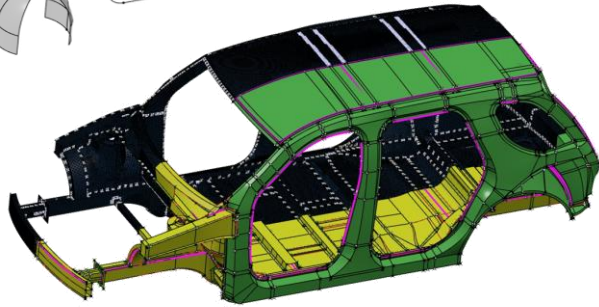
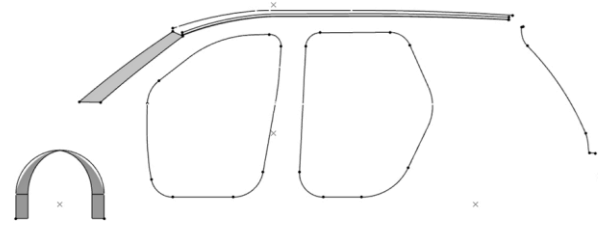
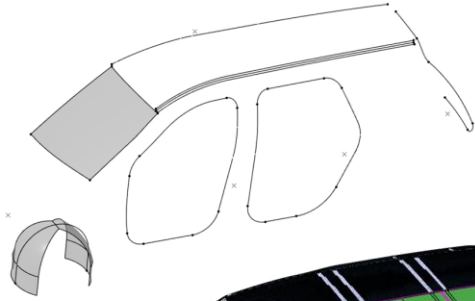



# WHEELBASE REAR

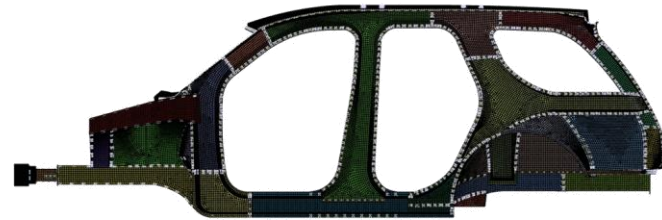
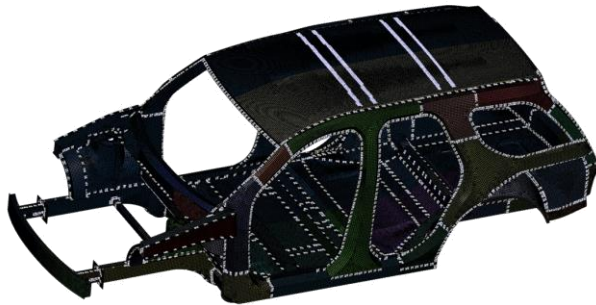
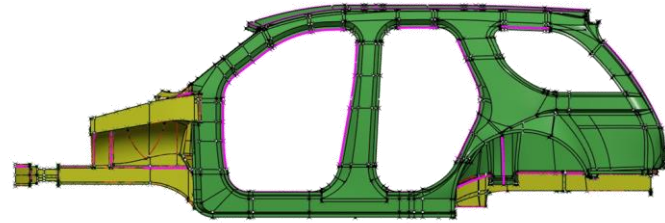
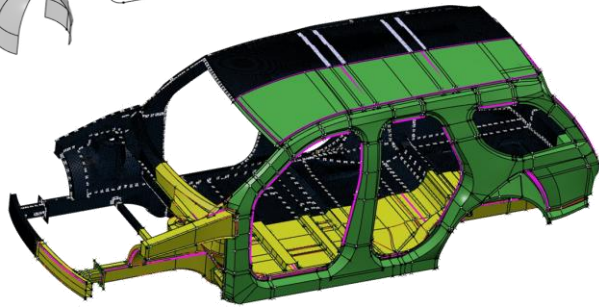
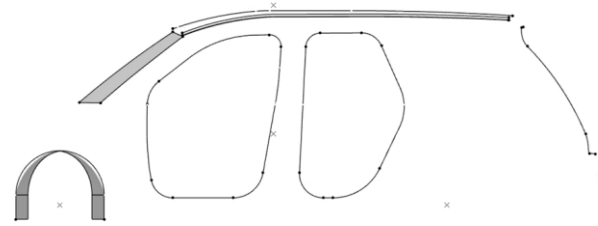
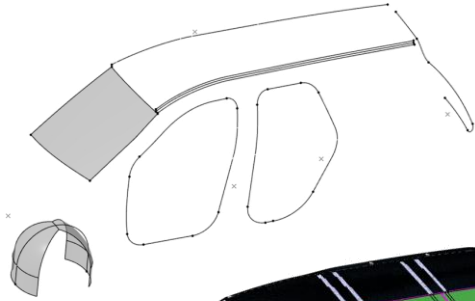

# FRONT OVERHANG

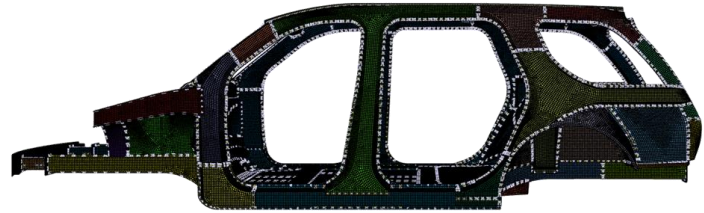
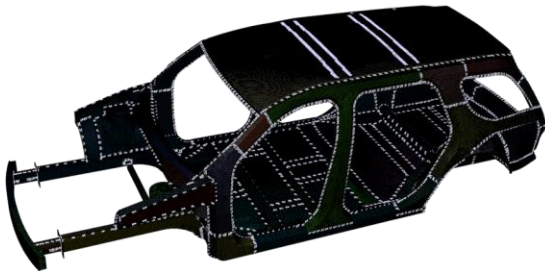
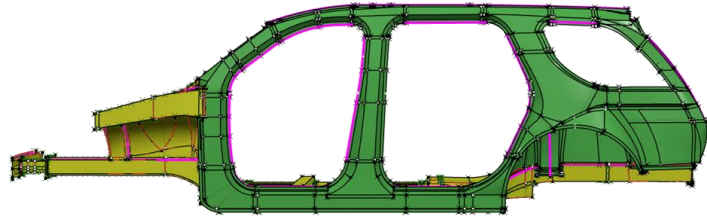
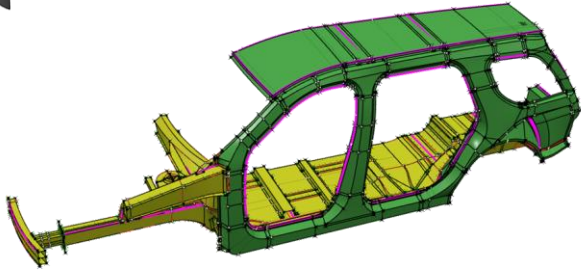
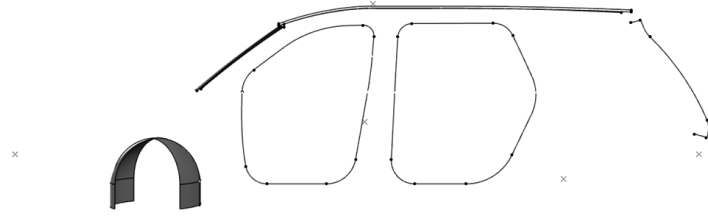
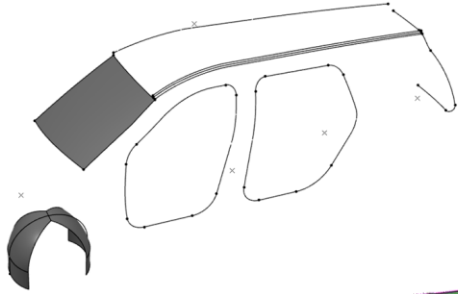

# ROOF HEIGHT

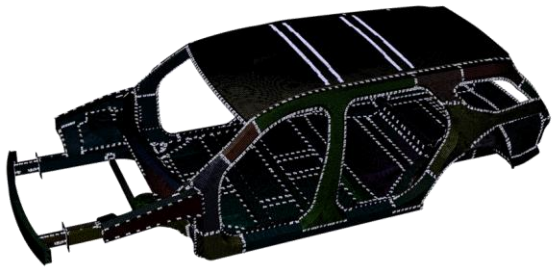
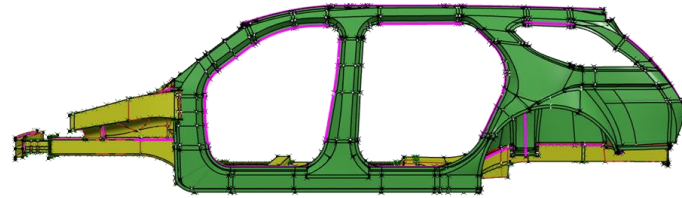
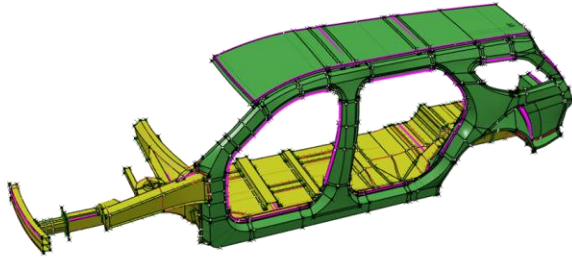
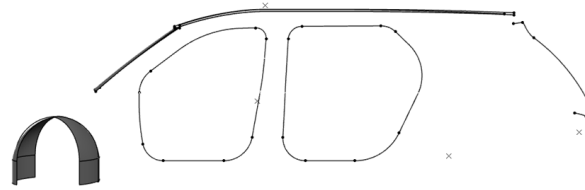
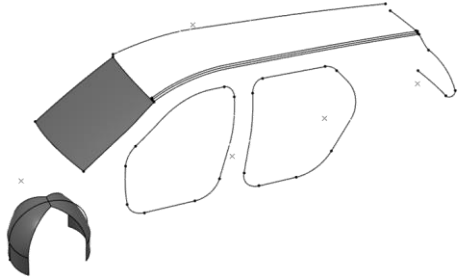

# TRACK WIDTH

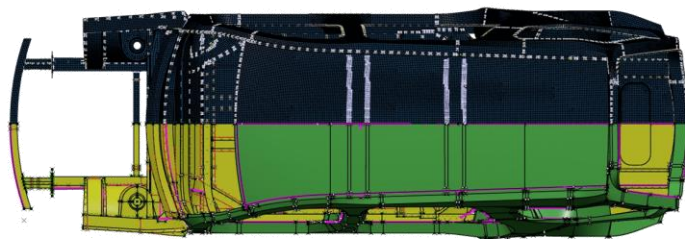
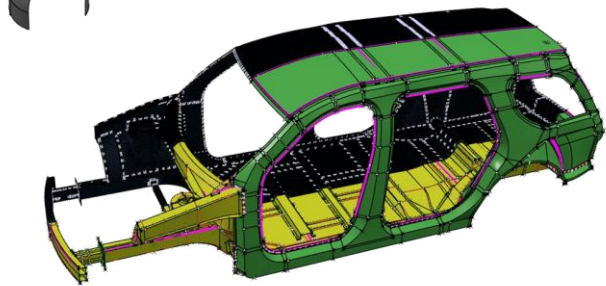
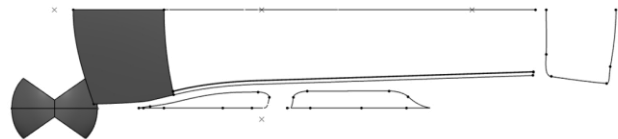
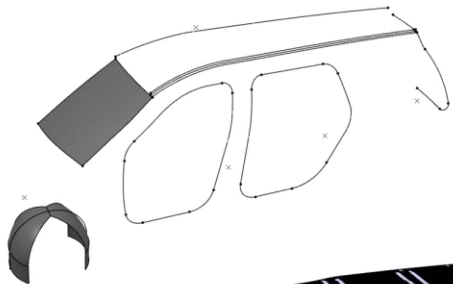

# ANY DISCIPLINE TO BE ASSESSED

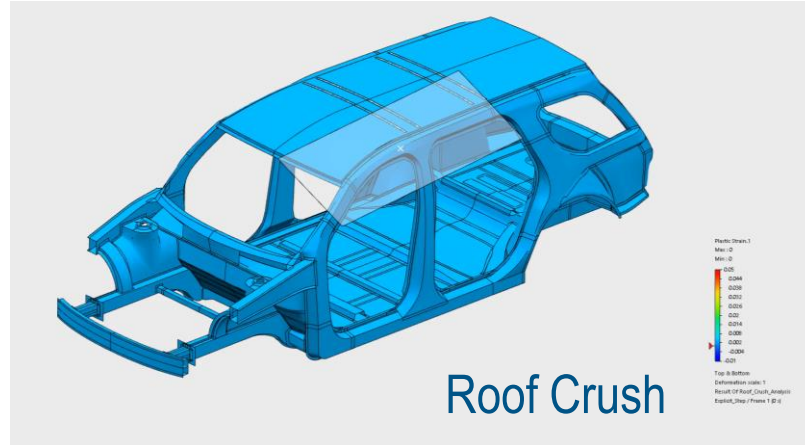
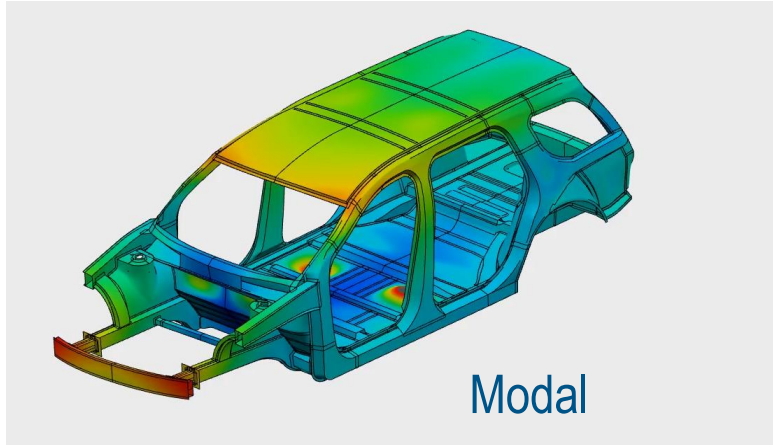
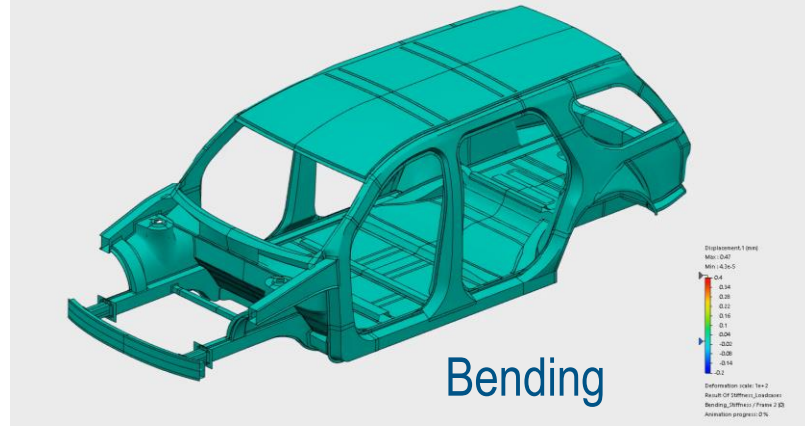
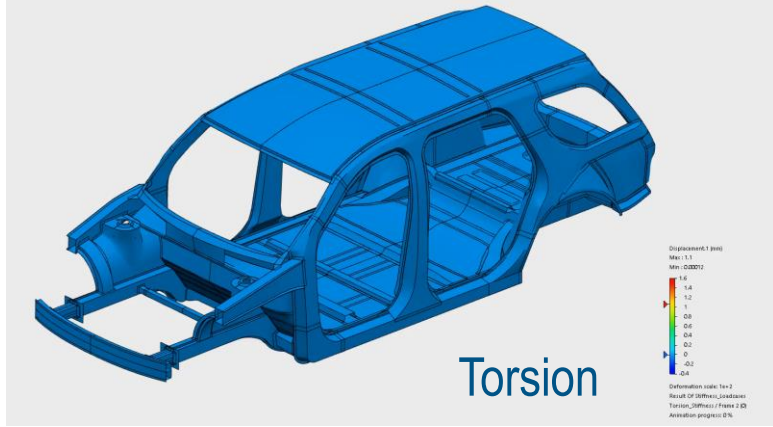

# PARAMETRIC CHANGE AND SIMULATION RESULTS

Displacement.8 (mm)  
Max : 0.826  
Min : 0



Deformation scale: 200

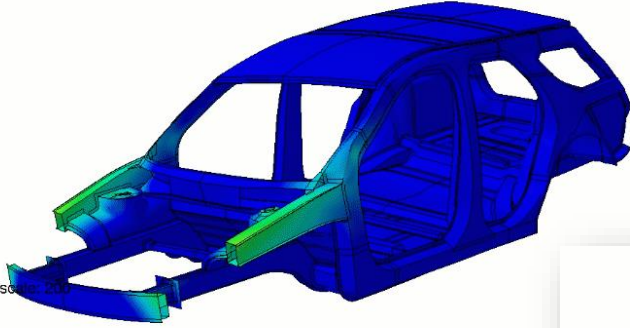

Name	Unit	Value
Feasibility		Best
Run phase		Completed
Rank		1
<input type="checkbox"/> Response Variables		
Mass_Mass Sensor_1	kg	289
Maximum_Displacement Magnitude_1	mm	3.783
Maximum_Von Mises Stress_1	n_...	1.485e+8
<input type="checkbox"/> Design Variables		
RearWheel_X	mm	2720
<input type="checkbox"/> Others		

Displacement.8 (mm)  
Max : 0.826  
Min : 0

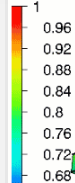

Deformation scale: 200

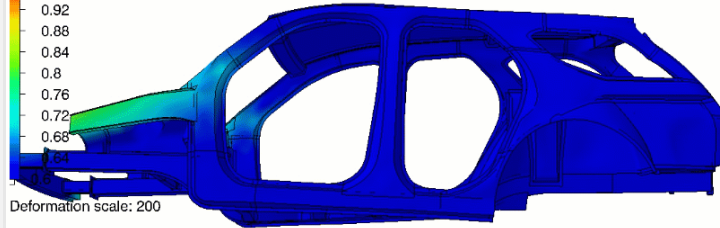

Name	Unit	Value
Feasibility		Best
Run phase		Completed
Rank		1
<input type="checkbox"/> Response Variables		
Mass_Mass Sensor_1	kg	289
Maximum_Displacement Magnitude_1	mm	3.783
Maximum_Von Mises Stress_1	n_...	1.485e+8
<input type="checkbox"/> Design Variables		
RearWheel_X	mm	2720
<input type="checkbox"/> Others		

## Torsion

# PARAMETRIC CHANGE AND SIMULATION RESULTS

Displacement.2 (mm)

Max : 3.78

Min : 0

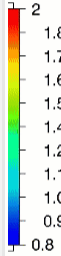

Deformation scale: 200

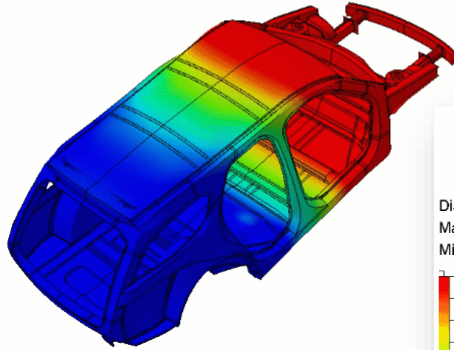

## Bending

Name	Unit	Value
Feasibility		Best
Run phase		Completed
Rank		1
<input type="checkbox"/> Response Variables		
Mass_Mass Sensor_1	kg	289
Maximum_Displacement Magnitude_1	mm	3.783
Maximum_Von Mises Stress_1	n_...	1.485e+8
<input type="checkbox"/> Design Variables		
RearWheel_LX	mm	2720
<input type="checkbox"/> Others		

Displacement.2 (mm)

Max : 3.78

Min : 0

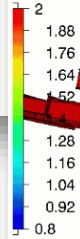

Deformation scale: 200

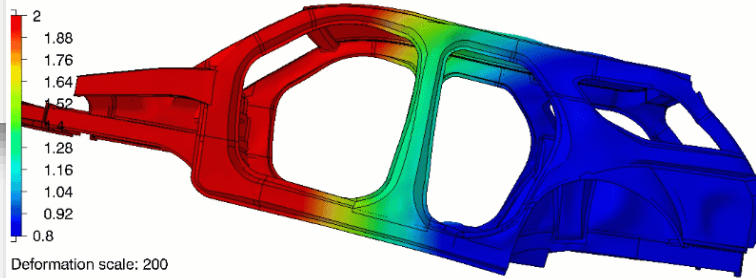

Name	Unit	Value
Feasibility		Best
Run phase		Completed
Rank		1
<input type="checkbox"/> Response Variables		
Mass_Mass Sensor_1	kg	289
Maximum_Displacement Magnitude_1	mm	3.783
Maximum_Von Mises Stress_1	n_...	1.485e+8
<input type="checkbox"/> Design Variables		
RearWheel_LX	mm	2720
<input type="checkbox"/> Others		

# TAKEAWAYS

- Vehicle architecture teams can work together with body designers and analysts
- Start program by template of an highly flexible architecture model adapting to architectural changes
- Concept Engineering on 3DEXPERIENCE allows to link architecture data dynamically to concept design, simulation and even DoE or optimization procedures

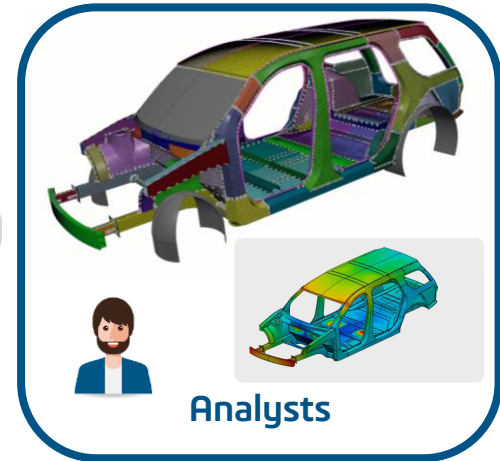
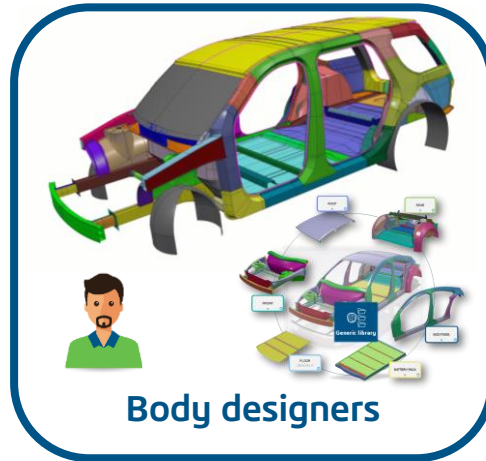
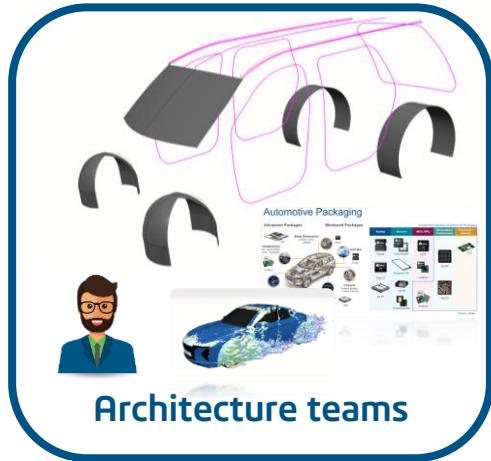



THANK YOU FOR YOUR INTEREST

